

## Planetary Mixers

### Planetary Mixer for Bakery, 40 lt. - Electronic + hub (Marine)

ITEM # \_\_\_\_\_

MODEL # \_\_\_\_\_

NAME # \_\_\_\_\_

SIS # \_\_\_\_\_

AIA # \_\_\_\_\_

**600299 (MBE40S06NC)**

40 lt Planetary Mixer, bowl detection device and SOLID BPA free safety screen, with 3 fixed speeds and electronic variable speed. Equipped with spiral hook, paddle, reinforced whisk and H type accessory hub. Suitable for bakery preparation - Marine

### Short Form Specification

#### Item No.

Suitable for bakery and pastry making, for kneading, blending and whipping operations. Reinforced body for heavy duty use with 18/8 (AISI 302) 40 litre capacity stainless steel bowl. Reinforced transmission and powerful asynchronous motor (2200W) with 3 fixed speeds (40,80,160 rpm) and electronic variable speed (from 30 to 175 rpm). Water proof (IP55) and flat touch button control panel with a timer from 0-59 min. Pivoting and removable wire safety screen. Kneading: speed 1 or 2 with hook; Blending: speed 2 with paddle; Whipping: speed 3 with whisk. Equipped with accessory drive hub type H (accessories are not included). Supplied with 3 tools: spiral hook, paddle and reinforced whisk.

### Main Features

- Emulsifying speed: "3" with whisk.
- Raising and lowering of the bowl controlled by lever with an automatic locking of the bowl when in the raised position.
- Kneading speed: "1" with hook.
- Mixing speed: "2" with paddle.
- Pivoting and removable wire safety screen for easier and better cleaning.
- Safety device will automatically stop the machine when the bowl is lowered.
- Wire safety screen fitted with a removable chute to add products while working, thus ensuring operator safety.
- Waterproof touch button control panel with timer, speed setting and display.
- Professional beater mixer designed to withstand the strong demands of bakery and pastry making.
- Delivered with:
  - Spiral Hook, Paddle, Reinforced Whisk and Mixing Bowl for 40 lt
- Maximum capacity (flour, with 60% of hydration) 10 kg.

### Construction

- Reinforced body, feet and transmission for heavy duty operations.
- 302 AISI Stainless steel bowl - 40 lt. capacity.
- Electronic speed variator (10 speeds available from 30 to 175 rpm)
- 3 fixed speeds: 40, 80 and 160 rpm.
- Water protected planetary system (IP55 electrical controls, IP23 overall machine).
- Power: 2200 watts.

### Included Accessories

- 1 of Bowl 40 lt PNC 650128
- 1 of Spiral Hook 40 lt PNC 653092
- 1 of Paddle 40 lt PNC 653093
- 1 of Reinforced Whisk 40 lt (for PNC 653127 heavy duty use)

### Optional Accessories

- 20 lt reduction kit (bowl, spiral hook, paddle, whisk) for 40 lt planetary mixers - bakery models PNC 650126
- Bowl 40 lt PNC 650128
- Bowl scraper 40 lt PNC 650186
- Spiral Hook 40 lt PNC 653092
- Paddle 40 lt PNC 653093
- Fine Whisk 40 lt (for emulsions) PNC 653094
- Reinforced Whisk 40 lt (for heavy duty use) PNC 653127

APPROVAL: \_\_\_\_\_

- Puree strainer for H hub supplied with 1 screw and 3 grids of 1.5, 3 and 6 mm PNC 653187
- Vegetable cutter, attachment type H, disconnectable drive, for planetary mixers PNC 653225
- Bowl trolley for 40/60/80 lt planetary mixers PNC 653585
- Aluminium external support for 70 mm meat mincer (includes tray and pusher) - H HUB - To be combined with a meat mincer kit PNC 653720
- Aluminium meat mincer kit 70 mm - Enterprise cut, includes blade (3 discs, diam. 4.5 - 6 and 8 mm) PNC 653721
- Stainless steel meat mincer kit 70 mm - Enterprise cut, includes blade (3 discs, diam. 4.5 - 6 and 8 mm) PNC 653722
- Stainless steel meat mincer kit 70 mm - 1/2 Unger cut, includes blade (4 discs, diam. 0, 3 - 4.5 and 8 mm) PNC 653723
- Aluminium external support for 82 mm meat mincer (includes tray and pusher) - H HUB - To be combined with a meat mincer kit PNC 653724
- Stainless steel meat mincer kit 82 mm - Enterprise cut, includes blade (3 discs, diam. 4.5 - 6 and 8 mm) PNC 653725
- Aluminium meat mincer kit 82 mm - Enterprise cut, includes blade (3 discs, diam. 4.5 - 6 and 8 mm) PNC 653726
- Stainless steel meat mincer kit 82 mm - 1/2 Unger cut, includes blade (4 discs, diam. 0, 3 - 4.5 and 8 mm) PNC 653727

Front

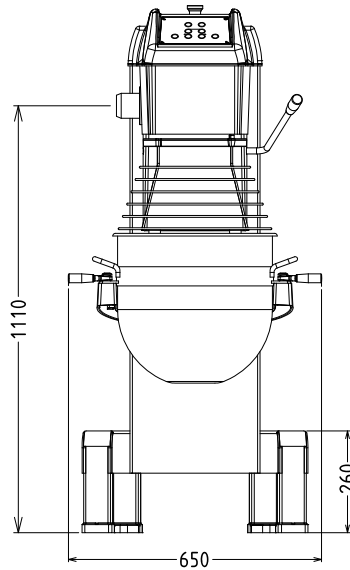
**Electric**
**Supply voltage:**

600299 (MBE40S06NC) 380-480 V/3 ph/50/60 Hz

**Electrical power max.:** 2.2 kW

**Total Watts:** 2.2 kW

**Capacity:**
**Performance (up to):** ISO 9001; ISO 14001 kg/  
Cycle

**Capacity:** 40 litres

**Key Information:**
**External dimensions, Width:** 655 mm

**External dimensions, Depth:** 850 mm

**External dimensions, Height:** 1370 mm

**Shipping weight:** 204 kg

**Cold water paste:** ISO 9001; ISO 14001 kg with  
Spiral hook

**Egg whites:** 70 with Whisk

Side

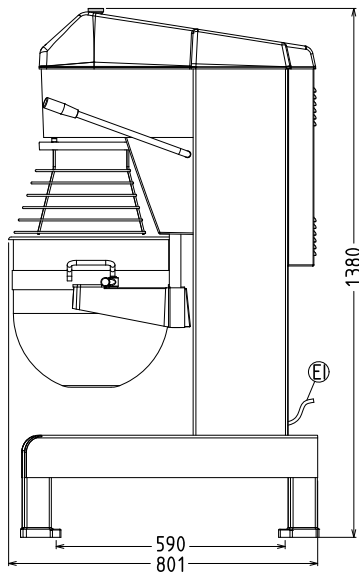

EI = Electrical inlet (power)

Top

